

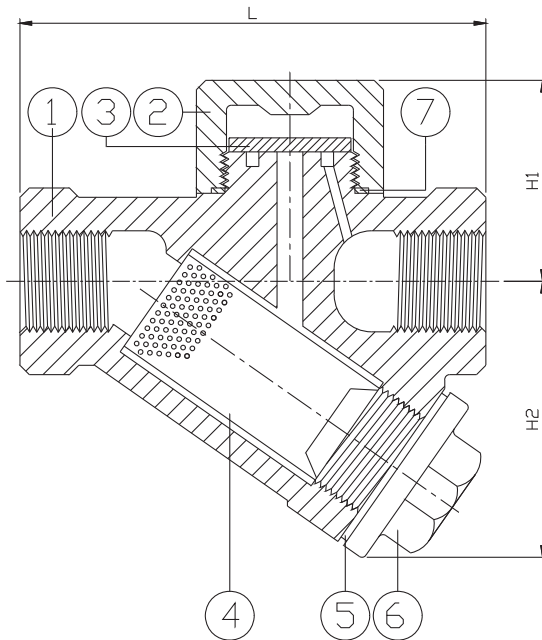

FEATURES



- 1/2"~2" (DN15~DN50)
- W.P. : 600 WOG
- Investment casting
- **End connections :**
 Flanged End - 2049TF
- Thread type : ASME B1.20.1 (NPT)
 DIN2999 & BS21
 ISO228/1 & ISO7/1



ITEM	PARTS	MATERIAL
1	BODY	ASTMA351-CF8M
2	CAP	
3	DISC	AISI 420
4	SCREEN	AISI 316
5	SEAL	ASBESTOS/ NON ASBESTOS
6	STRAINER CAP	ASTMA351-CF8M
7	WASHER	ASBESTOS

DN	15	20	25
L	78	88	98
H1	46	49	51
H2	53	87	63
Weight (kg)	1	1.1	1.4

unit:mm

NPS	1/2"	3/4"	1"
L	3.07	3.46	3.86
H1	1.81	1.93	2.01
H2	2.09	3.43	2.48
Weight (lb)	2.20	2.43	3.09

unit:in

CAPACITY			kg/h
SIZE	1/2"	3/4"	1"
1kg	190	290	450
2kg	220	360	510
3kg	250	400	720
4kg	270	440	780
5kg	295	460	850
7kg	320	500	980
10kg	350	530	1100
12kg	380	560	1160
16kg	530	850	1190
20kg	570	880	1250
32kg	600	930	1350
35kg	620	950	1460
40kg	690	980	1600

