



# FLANGED END SWING CHECK VALVE

# 2024

## FEATURES



- 1/2"~36" (DN15~DN900)
- W.P. : PN10/16/25/40  
CLASS 150/300/600/900/1500  
JIS 10K/20K
- W.T. : -20°C~200°C (-4°F~392°F)
- Investment casting
- API 6D / API 600 / API 602 (option)

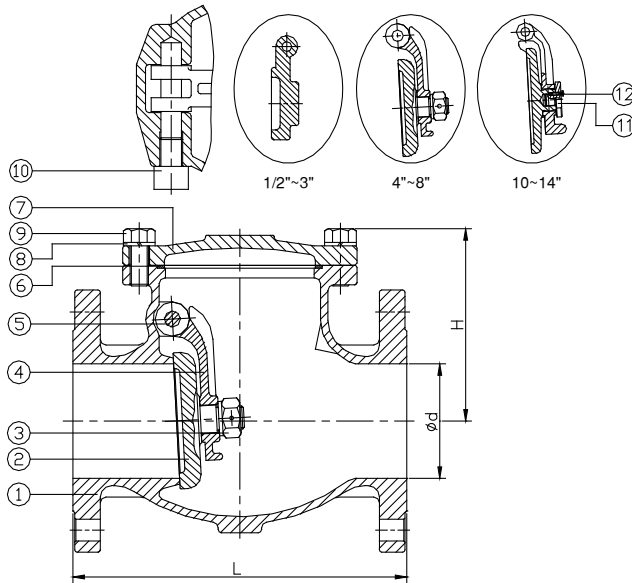

ITEM	PARTS	MATERIAL	
1	BODY	ASTM A351-CF8M	ASTM A351-CF8
2	DISC	1.4408	1.4308
3	NUT	AISI 304	
4	ARM HINGE	ASTM A351-CF8M	ASTM A351-CF8
		1.4408	1.4308
5	HINGE PIN	AISI 316	AISI 304
6	SEAL	PTFE / 304+GRAPHITE	
7	BONNET	ASTM A351-CF8M	ASTM A351-CF8
		1.4408	1.4308
8	SPRING WASHER	AISI 304	
9	BONNET BOLT		
10	BOLT		
11	DISC CAP	ASTM A351-CF8M	ASTM A351-CF8
12	BOLT	AISI 304	

\* 8" UP SEAL : 304+GRAPHITE

CLASS 150/300 PN16 ONLY, OTHER PRESSURE RATING PLEASE CONTACT US.

DN	d	L			H		
		CLASS 150	CLASS 300	PN16	CLASS 150	CLASS 300	PN16
15	15	108	152	130	51	61	51
20	20	117	178	150	54	61	54
25	25	127	203	160	64	79	64
32	32	140	-	180	68	-	68
40	40	165	229	200	75	93	75
50	50	203	267	230	98	127	98
65	65	216	292	290	112	144	112
80	80	241	318	310	124	154	124
100	100	292	356	350	161	196	161
125	125	330	400	400	180	217	179
150	150	356	444	480	205	230	205
200	200	495	533	600	236	265	236
250	250	622	622	730	302	319	302
300	300	698	-	850	340	-	340
350	337	787	-	-	385	-	-

unit:mm

NPS	d	L			H		
		CLASS 150	CLASS 300	PN16	CLASS 150	CLASS 300	PN16
1/2"	0.59	4.25	5.98	5.12	2.01	2.4	2.01
3/4"	0.79	4.61	7.01	5.91	2.13	2.4	2.13
1"	0.98	5	7.99	6.3	2.52	3.11	2.52
1-1/4"	1.26	5.51	-	7.09	2.68	-	2.68
1-1/2"	1.57	6.5	9.02	7.87	2.95	3.66	2.95
2"	1.97	7.99	10.51	9.06	3.86	5	3.86
2-1/2"	2.56	8.5	11.5	11.42	4.41	5.67	4.41
3"	3.15	9.49	12.52	12.2	4.88	6.06	4.88
4"	3.94	11.5	14.02	13.78	6.34	7.72	6.34
5"	4.92	12.99	15.75	15.75	7.09	8.54	7.05
6"	5.91	14.02	17.48	18.9	8.07	9.06	8.07
8"	7.87	19.49	20.98	23.62	9.29	10.43	9.29
10"	9.84	24.49	24.49	28.74	11.89	12.56	11.89
12"	11.81	27.48	-	33.46	13.39	-	13.39
14"	13.27	30.98	-	-	15.16	-	-

unit:in



8F, No.201, Sec. 2, Tiding Blvd., Neihu District, Taipei City 114, Taiwan R.O.C.  
TEL: +886-2-2658-5800 FAX: +886-2-2658-2266 / 2799-7766

E-mail : [haitima@seed.net.tw](mailto:haitima@seed.net.tw)  
<http://www.haitima.com.tw>