

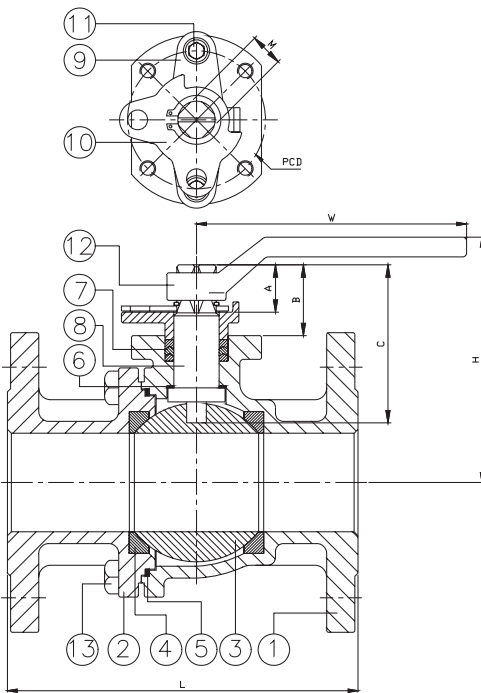

## FEATURES

- Full port, 1/2"~12" (DN15~DN300)
- W.P. : CLASS 150/300
- W.T. : -20°C~200°C (-4°F~392°F)
- Investment casting
- Blow-out proof stem
- Anti-static device (option)
- ISO 5211 Mounting pad
- Flange dimension: ASME B16.5
- Face to face: ASME B16.10



ITEM	PARTS	MATERIAL	
1	BODY	ASTM A351-CF8M	ASTM A216-WCB
2	CAP		
3	BALL	ASTM A351-CF8M	
4	SEAT	RTFE	
5	SEAL	PTFE	
6	THRUST WASHER		
7	PACKING		
8	STEM	ASTM A276-316	
9	GLAND	ASTM A351-CF8	
10	LOCKING PAD	ASTM A276-316	
11	GLAND BOLT	AISI 304	
12	HANDLE	ASTM A36(A536)	
13	BOLT	AISI 304	

DN	L (Class150)	L (Class300)	H	W	PCD	M	A	B	C	Torque (N-M)	Weight (kg) (Class150)	Weight (kg) (Class300)
15	108	140	73	130	42	11	17.3	24.3	50	4	1.7	2.5
20	117	153	76	130	42	11	17.3	25.5	50	4	2	3.5
25	127	165	86	160	50	14	23.1	30.8	63.5	10	3	4.7
32	140	-	91	160	50	14	20.5	31	63.5	20	3.8	-
40	165	190	119	205	70	17	28.4	41.5	81	20	6	9.3
50	178	216	127	205	70	17	28.4	41	81	40	8.5	11.7
65	190	241	136	325	70	17	28.4	42.5	88	55	13.7	13.6
80	203	282	164	325	102	22	39.3	56	112	80	18.2	26.3
100	229	305	178	325	102	22	38.1	56	112	120	28	39.3

unit:mm

NPS	L (Class150)	L (Class300)	H	W	PCD	M	A	B	C	Torque (in-lb)	Weight (kg) (Class150)	Weight (kg) (Class300)
1/2"	4.25	5.51	2.87	5.12	1.65	0.43	0.68	1	1.97	35.4	3.8	5.4
3/4"	4.61	6.02	2.99	5.12	1.65	0.43	0.68	1	1.97	35.4	4.5	7.6
1"	5	6.5	3.39	6.3	1.97	0.55	0.91	1.21	2.5	88.5	6.6	10.4
1-1/4"	5.51	-	3.58	6.3	1.97	0.55	0.81	1.2	2.5	177	8.3	-
1-1/2"	6.5	7.48	4.69	8.07	2.76	0.67	1.12	1.63	3.19	177	13.3	20.5
2"	7.01	8.5	5	8.07	2.76	0.67	1.12	1.61	3.19	354	18.7	25.8
2-1/2"	7.48	9.49	5.35	12.8	2.76	0.67	1.12	1.67	3.46	486.8	30.1	29.9
3"	7.99	11.1	6.46	12.8	4.02	0.87	1.55	2.2	4.41	708.1	40.2	57.9
4"	9.02	12.01	7.01	12.8	4.02	0.87	1.5	2.2	4.41	1062.1	61.7	86.6

unit:in