



1-PC. SCREWED END BALL VALVE

2017P



FEATURES

- Reduced port, 1/4"~2" (DN8~DN50)
- W.P. : 1000 WOG (PN63)
- W.T. : -20°C~200°C (-4°F~392°F)
- Investment casting
- Blow-out proof stem
- Anti-static device (option)
- **Polished body**
- Thread type : ASME B1.20.1 (NPT)
DIN2999 & BS21
ISO228/1 & ISO7/1

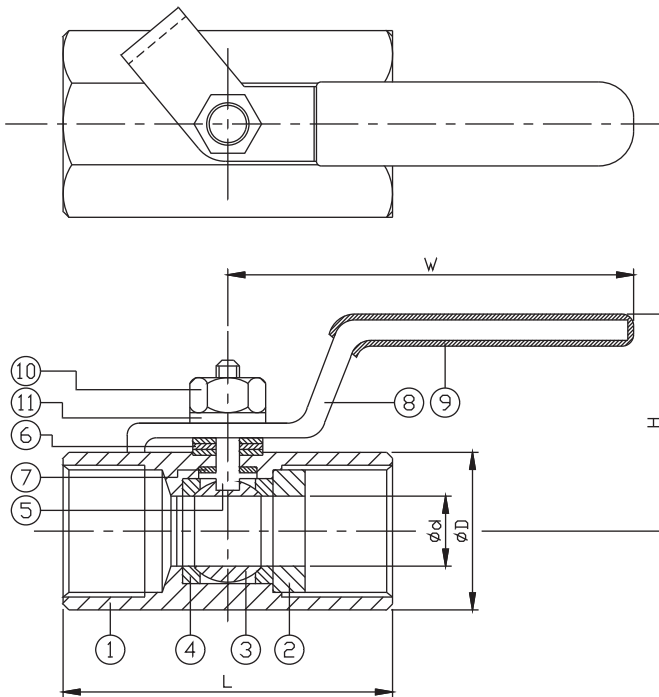

ITEM	PARTS	MATERIAL	
1	BODY	ASTM A351-CF8M	ASTM A216-WCB
2	SEAT RETAINER		
3	BALL	AISI 316	
4	SEAT	PTFE	
5	STEM	AISI 316	
6	PACKING	PTFE	
7	THRUST WASHER		
8	HANDLE	AISI 304	
9	HANDLE SLEEVE	PVC	
10	NUT	AISI 304	
11	WASHER		

DN	D	d	L	H	W	Weight(Kg)	Torque (N-m)	
							Breakaway	Action
8	18	5	39	32	66	0.07	5	4
10	21	7.2	50	33	81	0.12	8	6
15	24	9.2	56.5	55	107	0.2	9	7
20	32	12.5	59.3	66	107	0.29	20	15
25	37	15	71	70	120	0.43	40	30
32	48	20	78	72	120	0.71	62	47
40	53	25	83	72	147	0.84	78	58
50	65	32	99	82	152	1.35	90	67

unit:mm

NPS	D	d	L	H	W	Weight(lb)	Torque (in-lb)	
							Breakaway	Action
1/4"	0.71	0.2	1.54	1.26	2.6	0.15	49.26	40.4
3/8"	0.83	0.28	1.97	1.30	3.19	0.26	75.81	58.11
1/2"	0.94	0.36	2.22	2.17	4.21	0.44	84.66	66.96
3/4"	1.26	0.49	2.33	2.60	4.21	0.64	182.02	137.77
1"	1.46	0.59	2.8	2.76	4.72	0.95	359.04	270.53
1-1/4"	1.89	0.79	3.07	2.83	4.72	1.57	553.76	421
1-1/2"	2.09	0.98	3.27	2.83	5.79	1.85	695.38	518.36
2"	2.56	1.26	3.9	3.23	5.98	2.98	801.59	598.02

unit:in



8F., No.201, Sec. 2, Tiding Blvd., Neihu District, Taipei City 114, Taiwan R.O.C.
 TEL: +886-2-26585800 FAX: +886-2-26582266 / 27997766

[Http://www.haitima.com.tw](http://www.haitima.com.tw)
 Email: haitima@seed.net.tw