



# 1-PC. SCREWED END BALL VALVE

# 2017



## FEATURES

- Reduced port, 1/4"~2" (DN8~DN50)
- W.P. : 1000 WOG (PN63)
- W.T. : -20°C~200°C (-4°F~392°F)
- Investment casting
- Blow-out proof stem
- Anti-static device (option)
- Thread type : ASME B1.20.1 (NPT)  
DIN2999 & BS21  
ISO228/1 & ISO7/1

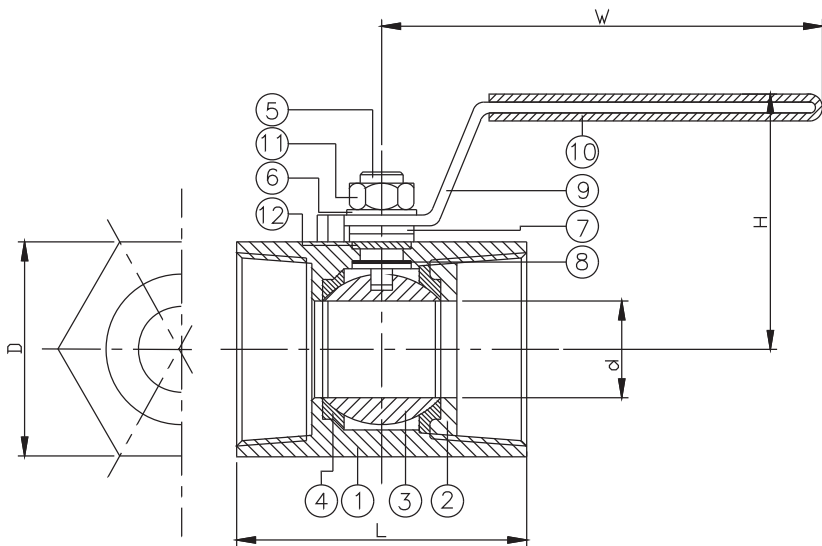

ITEM	PARTS	MATERIAL	
1	BODY	ASTM A351-CF8M	ASTM A216-WCB
2	SEAT RETAINER		
3	BALL	ASTM A351-CF8M	
4	SEAT	PTFE	
5	STEM	AISI 316	
6	SPRING WASHER		
7	GLAND RING	AISI 304	
8	THRUST WASHER	PTFE	
9	HANDLE	AISI 304	
10	HANDLE SLEEVE	PVC	
11	STEM NUT	AISI 304	
12	PACKING	PTFE	

DN	D	d	L	H	W	Torque (N-m)	
						Breakaway	Action
8	17	5	39	30.5	70	0.49	0.39
10	21	7.2	44	31	81.5	0.78	0.59
15	25	9.2	56.5	47	97	0.88	0.69
20	32	12.5	59	51	97	1.96	1.47
25	38	15	71	52	101	3.92	2.94
32	48	20	78	57	101	6.08	4.61
40	53	25	83	66.5	146	7.64	5.68
50	64	32	100	71.5	146	8.82	6.57

unit:mm

NPS	D	d	L	H	W	Torque (in-lb)	
						Breakaway	Action
1/4"	0.67	0.2	1.54	1.2	2.76	4.34	3.45
3/8"	0.83	0.28	1.73	1.22	3.21	6.9	5.22
1/2"	0.98	0.36	2.22	1.85	3.82	7.79	6.11
3/4"	1.26	0.49	2.32	2.01	3.82	17.35	13.01
1"	1.50	0.59	2.8	2.05	3.98	34.69	26.02
1-1/4"	1.89	0.79	3.07	2.24	3.98	53.81	40.8
1-1/2"	2.09	0.98	3.27	2.62	5.75	67.62	50.27
2"	2.52	1.26	3.94	2.81	5.75	78.06	58.15

unit:in



8F., No.201, Sec. 2, Tiding Blvd., Neihu District, Taipei City 114, Taiwan R.O.C.  
 TEL: +886-2-26585800 FAX: +886-2-26582266 / 27997766

[Http://www.haitima.com.tw](http://www.haitima.com.tw)  
 Email: [haitima@seed.net.tw](mailto:haitima@seed.net.tw)