



3-PC. SCREWED END BALL VALVE

2013N

★ ECONOMIC PATTERN

FEATURES



- Full port, 1/4"~4" (DN8~DN100)
- W.P. : 1000 WOG (PN63)
- W.T. : -20°C~200°C (-4°F~392°F)
- Investment casting
- Blow-out proof stem
- Locking device
- **TA-Luft approved**
- **Length conform to DIN 3202/4-M3-2013N-M3 (option)**
- Thread type : ASME B1.20.1 (NPT)
DIN2999 & BS21
ISO228/1 & ISO7/1

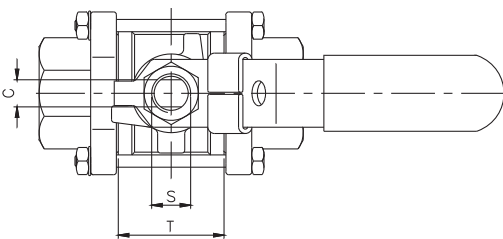
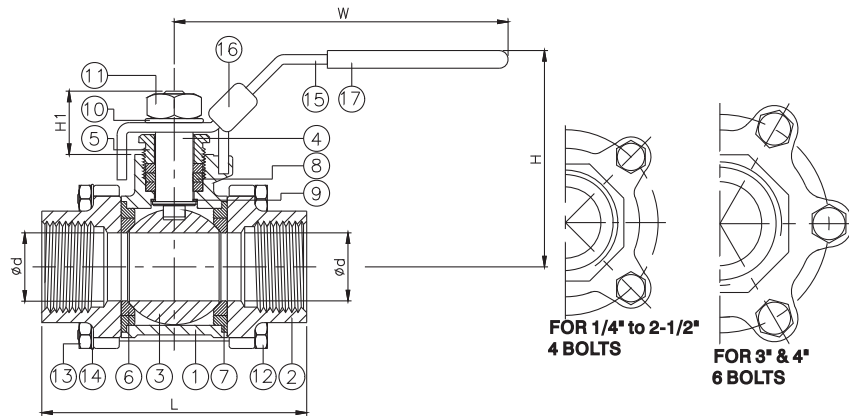

ITEM	PARTS	MATERIAL	
1	BODY	ASTM A351-CF8M	ASTM A216-WCB
2	CAP		
3	BALL	ASTM A351-CF8M	
4	STEM	ASTM A276-316	
5	GLAND NUT	AISI 304	
6	SEAT	PTFE / RTFE	
7	SEAL		
8	PACKING	PTFE	
9	THRUST WASHER		
10	SPRING WASHER		
11	STEM NUT		
12	BOLT		
13	NUT	AISI 304	
14	SPRING WASHER		
15	HANDLE		
16	LOCKING DEVICE		
17	HANDLE SLEEVE	PVC	

DN	d	L	H	H1	W	T	C	S	Torque (N-M)	Weight (kg)
8	11.6	65	58.5	18	100	21.6	5	3/8"-24UNF	3.5	0.35
10	12.5	65	58.5	18	100	21.6	5	3/8"-24UNF	4	0.35
15	15	65	62	18.5	100	24	5	3/8"-24UNF	5.5	0.5
20	20	75	62	22.5	125	29.7	6.5	7/16"-20UNF	7.5	0.7
25	25	85	77	25	149	34.4	7.9	7/16"-20UNF	11	1
32	32	101	82	26	149	42.8	7.9	7/16"-20UNF	15	1.6
40	38	112	100	30	190	51.1	10	1/2"-20UNF	20	2.5
50	50	130	108	30	190	63.4	10	1/2"-20UNF	40	3.5
65	63	162	137	40	250	81.2	12	3/4"-10UNC	60	6.7
80	76	188	145	40	250	95.6	12	3/4"-10UNC	85	9.5
100	96	224	179	54	323	127.1	16	1"-8UNC	150	19.1

unit:mm

NPS	d	L	H	H1	W	T	C	S	Torque (in-lb)	Weight (lb)
1/4"	0.46	2.56	2.3	0.71	3.94	0.85	0.2	3/8"-24UNF	30.98	0.77
3/8"	0.49	2.56	2.3	0.71	3.94	0.85	0.2	3/8"-24UNF	35.4	0.77
1/2"	0.59	2.56	2.44	0.73	3.94	0.94	0.2	3/8"-24UNF	48.68	1.1
3/4"	0.79	2.95	2.44	0.89	4.92	1.17	0.26	7/16"-20UNF	66.38	1.54
1"	0.98	3.35	3.03	0.98	5.87	1.35	0.31	7/16"-20UNF	97.36	2.2
1-1/4"	1.26	3.98	3.23	1.02	5.87	1.69	0.31	7/16"-20UNF	132.76	3.53
1-1/2"	1.5	4.41	3.94	1.18	7.48	2.01	0.39	1/2"-20UNF	177.01	5.51
2"	1.97	5.12	4.25	1.18	7.48	2.5	0.39	1/2"-20UNF	354.03	7.72
2-1/2"	2.48	6.38	5.39	1.57	9.84	3.2	0.47	3/4"-10UNC	531.04	14.77
3"	2.99	7.4	5.71	1.57	9.84	3.76	0.47	3/4"-10UNC	752.31	20.94
4"	3.78	8.82	7.05	2.13	12.72	5	0.63	1"-8UNC	1327.61	42.11

unit:in



8F., No.201, Sec. 2, Tiding Blvd., Neihu District, Taipei City 114, Taiwan R.O.C.
 TEL: +886-2-26585800 FAX: +886-2-26582266 / 27997766

[Http://www.haitima.com.tw](http://www.haitima.com.tw)
 Email: haitima@seed.net.tw