

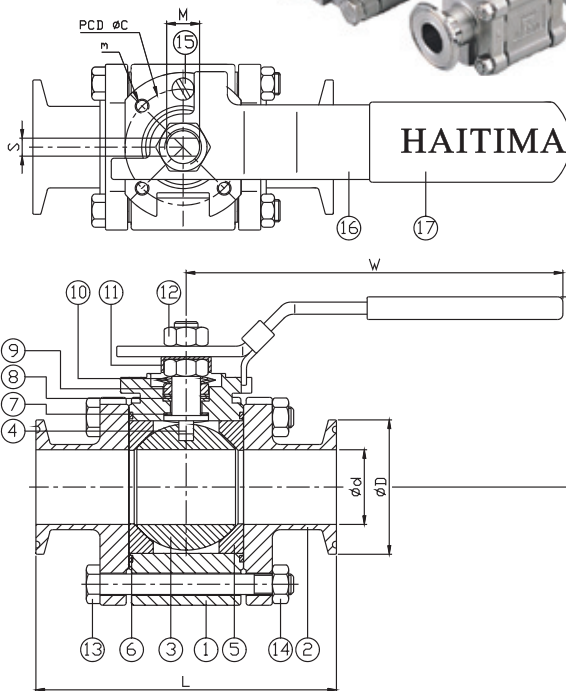

FEATURES

- Clamp end, 1/2"~2" (DN15~DN50)
- Body W.P. : 1000 WOG (PN63)
- Clamp End W.P. : 200 WOG
- W.T. : -20°C~200°C (-4°F~392°F)
- Investment casting
- Blow-out proof stem
- Live-loading design
- Anti-static device (option)
- Cavity filled seats (option)
- Locking device
- ISO 5211 Mounting pad



2013KC-BPE

- Clamp end castings have low sulphur content of 0.005-0.017%

ITEM	PARTS	MATERIAL
1	BODY	ASTM A351-CF3M
2	CAP	
3	BALL	
4	STEM	ASTM A276-316L
5	BALL SEAT	PTFE / TFM1600
6	GASKET	PTFE
7	THRUST WASHER	
8	PACKING	AISI 304
9	GLAND RING	
10	BELLEVILLE WASHER	AISI 301
11	LOCKING WASHER	AISI 304
12	STEM WASHER	
13	STEM NUT	
14	BOLT	
15	BOLT WASHER	
16	NUT	
17	STOP PIN	
18	LOCKING DEVICE	
19	HANDLE	
20	HANDLE SLEEVE	

DN	L	H	W	d	D	C	m	M	S	ISO5211	Torque(N-M)
15	88.9	53.5	114	9.4	25.4	36	M5	3/8"-24UNF	5.7	F03	4.5
20	101.6	55.0	114	15.75	25.4	36	M5	3/8"-24UNF	5.7	F03	6
25	121.9	66.0	146	22.1	50.4	42	M5	7/16"-20UNF	7.5	F04	11
32	130	70.0	146	28.5	50.4	42	M5	7/16"-20UNF	7.5	F04	12
40	139.7	81.0	178	34.8	50.4	50	M6	9/16"-18UNF	8.6	F05	15
50	158.76	89.5	178	47.5	63.9	50	M6	9/16"-18UNF	8.6	F05	22

unit:mm

NPS	L	H	W	d	D	C	m	M	S	ISO5211	Torque(in-lb)
1/2"	3.5	2.11	4.49	0.37	1	1.42	M5	3/8"-24UNF	0.23	F03	39.8
3/4"	4	2.17	4.49	0.62	1	1.42	M5	3/8"-24UNF	0.2	F03	53.1
1"	4.80	2.6	5.75	0.87	1.98	1.65	M5	7/16"-20UNF	0.3	F04	97.4
1-1/4"	5.12	2.76	5.75	1.12	1.98	1.65	M5	7/16"-20UNF	0.3	F04	106.2
1-1/2"	5.5	3.19	7.01	1.37	1.98	1.97	M6	9/16"-18UNF	0.34	F05	132.8
2"	6.25	3.52	7.01	1.87	2.52	1.97	M6	9/16"-18UNF	0.34	F05	194.7

unit:in