



3-PC. SCREWED END BALL VALVE

2013D



FEATURES

- Full port, 1/4"~2" (DN8~DN50)
- W.P. : 1000 WOG (PN63)
- W.T. : -20°C~200°C (-4°F~392°F)
- Investment casting
- Blow-out proof stem
- Live-loading device
- Anti-static device
- Locking device
- ISO 5211 Direct mounting pad
- Length conform to DIN 3202/4-M3
- **Automation accessories (option)**
- Thread type : ASME B1.20.1 (NPT)
DIN2999 & BS21
ISO228/1 & ISO7/1

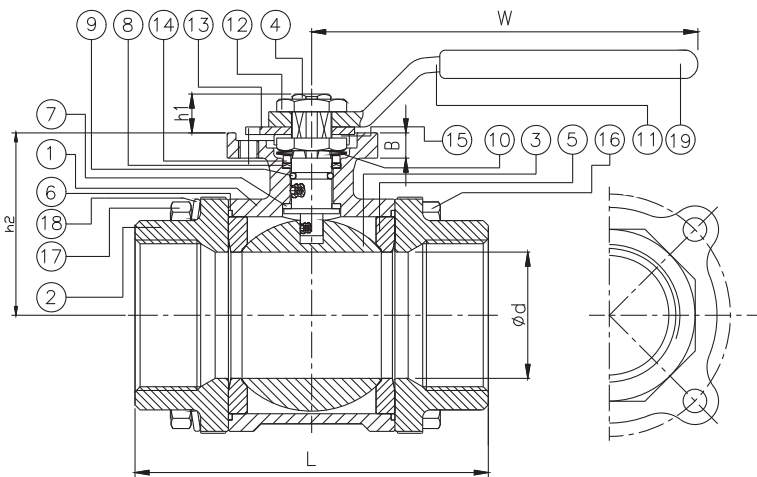
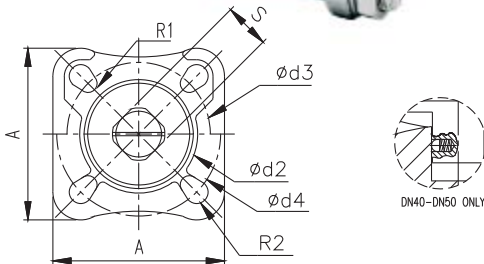

ITEM	PARTS	MATERIAL	
1	BODY	ASTM A351-CF8M	ASTM A216-WCB
2	CAP		
3	BALL	ASTM A351-CF8M	
4	STEM	ASTM A276-316	
5	SEAT	RTFE	
6	SEAL		
7	THRUST WASHER	PTFE	
8	PACKING		
9	O-RING	VITON	
10	BELLEVILLE WASHER	AISI 301	
11	HANDLE	ASTM A351-CF8	
12	STEM NUT		
13	LOCKING DEVICE		
14	GLAND RING		
15	LOCKING WASHER	AISI 304	
16	BOLT		
17	NUT		
18	SPRING WASHER		
19	HANDLE SLEEVE	PVC	

DN	d	L	W	ISO 5211	A	B	S	h1	h2	d2	d3	d4	R1	R2	Torque N-m	
															Action	Breakaway
8	8	55	120	F03/F04	42	6.5	9	8	40.3	31	36	42	2.75	2.75	2.47	3.64
10	10	60	120					9	45						4	6.11
15	15	75	120					10	47.5						4.29	9.88
20	20	80	120	F04/F05	50	7.5	11	11	55.5	35.5	42	50	2.75	3.5	11.7	15.6
25	25	90	148					12	65.3						14	22
32	32	110	148	F05/F07	70	9	14	12	73	56	50	70	3.5	4.5	14	22
40	38	120	178					19	26.78							
50	50	140	178													

unit:mm

NPS	d	L	W	ISO 5211	A	B	S	h1	h2	d2	d3	d4	R1	R2	Torque in-lb	
															Action	Breakaway
1/4"	0.31	2.17	4.72	F03/F04	1.65	0.26	0.35	0.31	1.59	1.22	1.42	1.65	0.11	0.11	21.9	32.2
3/8"	0.39	2.36	4.72					0.35	1.77						35.4	54.1
1/2"	0.59	2.95	4.72					0.39	1.87						38	87.4
3/4"	0.79	3.15	4.72	F04/F05	1.97	0.3	0.43	0.43	2.19	1.4	1.65	1.97	0.11	0.14	103.6	138.1
1"	0.98	3.54	5.83					0.47	2.57						123.9	194.7
1-1/4"	1.26	4.33	5.83	F05/F07	2.76	0.35	0.55	0.47	2.87	2.2	1.97	2.76	0.14	0.18	168.2	237
1-1/2"	1.5	4.72	7.01													
2"	1.97	5.51	7.01													

unit:in



8F., No.201, Sec. 2, Tiding Blvd., Neihu District, Taipei City 114, Taiwan R.O.C.
 TEL: +886-2-26585800 FAX: +886-2-26582266 / 27997766

[Http://www.haitima.com.tw](http://www.haitima.com.tw)
 Email: haitima@seed.net.tw