



## ★ ECONOMIC PATTERN

## FEATURES



- Full port, 1/4"~4" (DN8~DN100)
- W.P. : 1000 WOG (PN63)
- W.T. : -20°C~200°C (-4°F~392°F)
- Investment casting
- Blow-out proof stem
- Locking device
- **TA-Luft approved**
- **Length conform to DIN 3202/4-M3-2012N-M3 (option)**
- Butt weld ends conform to ANSI B16.25 & DIN 3239 part1

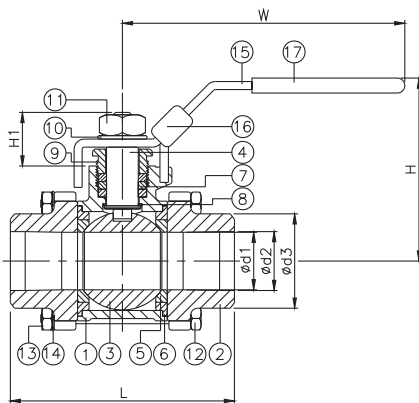

FOR 1/4" to 2-1/2" 4 BOLTS

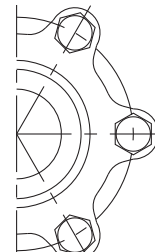

FOR 3" & 4" 6 BOLTS

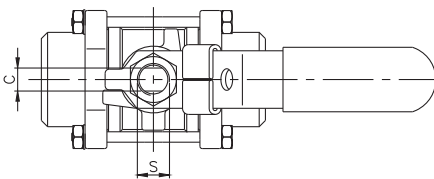

ITEM	PARTS	MATERIAL	
1	BODY	ASTMA351-CF8M	ASTMA216-WCB
2	CAP		
3	BALL	ASTMA351-CF8M	
4	STEM	ASTMA276-316	
5	SEAT	PTFE / RTFE	
6	SEAL	PTFE	
7	PACKING		
8	THRUST WASHER		
9	GLAND NUT		
10	SPRING WASHER	AISI 304	
11	STEM NUT		
12	BOLT		
13	NUT		
14	SPRING WASHER	PVC	
15	HANDLE		
16	LOCKING DEVICE		
17	HANDLE SLEEVE		

DN	d1	d2	d3	L	H	H1	W	C	S	Torque (N·M)	Weight (kg)
8	9.3	-	14.7	65	58.5	18	100	5	3/8"-24UNF	3.5	0.35
10	12.5	-	18.1	65	58.5	18	100	5	3/8"-24UNF	4	0.35
15	15	15.8	22.3	65	62	18.5	100	5	3/8"-24UNF	5.5	0.5
20	20	20.9	27.7	75	62	22.5	125	6.5	7/16"-20UNF	7.5	0.7
25	25	26.6	34.4	85	77	25	149	7.9	7/16"-20UNF	11	1
32	32	35.1	43.2	101	82	26	149	7.9	7/16"-20UNF	15	1.6
40	38	40.9	49.3	112	100	30	190	10	1/2"-20UNF	20	2.5
50	50	52.5	61.5	130	108	30	190	10	1/2"-20UNF	40	3.5
65	63	62.7	74.5	162	137	40	250	12	3/4"-10UNC	60	6.7
80	76	77.9	91	188	145	40	250	12	3/4"-10UNC	85	9.5
100	96	102	115.5	224	179	54	323	16	1"-8UNC	150	19.1

unit:mm

NPS	d1	d2	d3	L	H	H1	W	C	S	Torque (in·lb)	Weight (lb)
1/4"	0.37	-	0.58	2.56	2.3	0.71	3.94	0.2	3/8"-24UNF	30.98	0.77
3/8"	0.49	-	0.71	2.56	2.3	0.71	3.94	0.2	3/8"-24UNF	35.4	0.77
1/2"	0.59	0.62	0.88	2.56	2.44	0.73	3.94	0.2	3/8"-24UNF	48.68	1.1
3/4"	0.79	0.82	1.09	2.95	2.44	0.89	4.92	0.26	7/16"-20UNF	66.38	1.54
1"	0.98	1.05	1.35	3.35	3.03	0.98	5.87	0.31	7/16"-20UNF	97.36	2.2
1-1/4"	1.26	1.38	1.7	3.98	3.23	1.02	5.87	0.31	7/16"-20UNF	132.76	3.53
1-1/2"	1.5	1.61	1.94	4.41	3.94	1.18	7.48	0.39	1/2"-20UNF	177.01	5.51
2"	1.97	2.07	2.42	5.12	4.25	1.18	7.48	0.39	1/2"-20UNF	354.03	7.72
2-1/2"	2.48	2.47	2.93	6.38	5.39	1.57	9.84	0.47	3/4"-10UNC	531.04	14.77
3"	2.99	3.07	3.58	7.4	5.71	1.57	9.84	0.47	3/4"-10UNC	752.31	20.94
4"	3.78	4.02	4.55	8.82	7.05	2.13	12.72	0.63	1"-8UNC	1327.61	42.11

unit:in

