

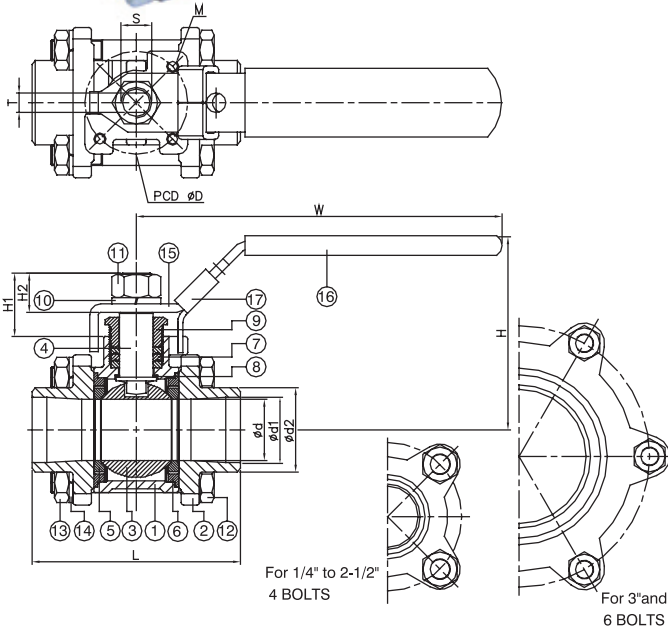

## ★ ECONOMIC PATTERN



## FEATURES

- Full port, 1/4"~4" (DN8~DN100)
- W.P. : 1000 WOG (PN63)
- W.T. : -20°C~200°C (-4°F~392°F)
- Investment casting
- Blow-out proof stem
- Locking device
- ISO 5211 Mounting pad
- TA-Luft approved (option)
- Length conform to DIN 3202/4-M3-2012NM-M3 (option)
- Butt weld ends conform to ANSI B16.25 & DIN 3239 part1

ITEM	PARTS	MATERIAL	
1	BODY	ASTM A351-CF8M	ASTM A216-WCB
2	CAP		
3	BALL	ASTM A351-CF8M	
4	STEM	ASTM A276-316	
5	SEAT	PTFE / RTFE	
6	SEAL		
7	PACKING	PTFE	
8	THRUST WASHER		
9	GLAND NUT		
10	SPRING WASHER		
11	STEM NUT		
12	BOLT	AISI 304	
13	NUT		
14	SPRING WASHER		
15	HANDLE		
16	HANDLE SLEEVE	PVC	
17	LOCKING DEVICE	AISI 304	

DN	d	d1	d2	D	M	L	H	W	S	T	H1	H2	ISO 5211	Torque (N-M)	Weight (kg)
8	11.6	14.5	-	36	M5	65	58.5	100	3/8"-24UNF	5	19.3	13.5	F03	7.5	0.4
10	12.5	18	-	36	M5	65	58.5	100	3/8"-24UNF	5	19.3	13.5	F03	7.5	0.4
15	15	22	15.8	36	M5	65	62	100	3/8"-24UNF	5	19.4	13.5	F03	7.5	0.5
20	20	27.5	20.9	36	M5	75	62	125	7/16"-20UNF	6.5	22.4	16	F03	7.5	0.7
25	25	34	26.6	42	M5	85	77	149	7/16"-20UNF	8	25.6	16.2	F04	12.5	1
32	32	43	35.1	42	M5	101	82	149	7/16"-20UNF	8	25.6	16.2	F04	15	1.7
40	38	49	40.9	50	M6	112	100	190	1/2"-20UNF	10	29.7	20	F05	20	2.4
50	50	61	52.5	50	M6	130	108	190	1/2"-20UNF	10	29.7	20	F05	25	3.5
65	63	74	62.7	70	M8	162	137	250	3/4"-10UNC	12	39.4	27.5	F07	64	6.7
80	76	90	77.9	70	M8	188	145	250	3/4"-10UNC	12	39.4	27.5	F07	85	9.8
100	96	116	102	102	M10	224	179	323	1"-8UNC	16	53.7	39.8	F10	95	19.2

unit:mm

NPS	d	d1	d2	D	M	L	H	W	S	T	H1	H2	ISO 5211	Torque (in-lb)	Weight (lb)
1/4"	0.46	0.57	-	1.42	M5	2.56	2.3	3.94	3/8"-24UNF	0.2	0.76	0.53	F03	66.4	0.8
3/8"	0.49	0.71	-	1.42	M5	2.56	2.3	3.94	3/8"-24UNF	0.2	0.76	0.53	F03	66.4	0.8
1/2"	0.59	0.87	0.62	1.42	M5	2.56	2.44	3.94	3/8"-24UNF	0.2	0.76	0.53	F03	66.4	1.1
3/4"	0.79	1.08	0.82	1.42	M5	2.95	2.44	4.92	7/16"-20UNF	0.26	0.88	0.63	F03	66.4	1.6
1"	0.98	1.34	1.05	1.65	M5	3.35	3.03	5.87	7/16"-20UNF	0.31	1.01	0.64	F04	110.6	2.3
1-1/4"	1.26	1.69	1.38	1.65	M5	3.98	3.23	5.87	7/16"-20UNF	0.31	1.01	0.64	F04	132.8	3.6
1-1/2"	1.5	1.93	1.61	1.97	M6	4.41	3.94	7.48	1/2"-20UNF	0.39	1.17	0.79	F05	177	5.3
2"	1.97	2.4	2.07	1.97	M6	5.12	4.25	7.48	1/2"-20UNF	0.39	1.17	0.79	F05	221.3	7.7
2-1/2"	2.48	2.91	2.47	2.76	M8	6.38	5.39	9.84	3/4"-10UNC	0.47	1.55	1.08	F07	566.4	14.8
3"	2.99	3.54	3.07	2.76	M8	7.4	5.71	9.84	3/4"-10UNC	0.47	1.55	1.08	F07	752.3	21.6
4"	3.78	4.57	4.02	4.02	M10	8.82	7.05	12.72	1"-8UNC	0.63	2.11	1.57	F10	840.8	42.3

unit:in

