

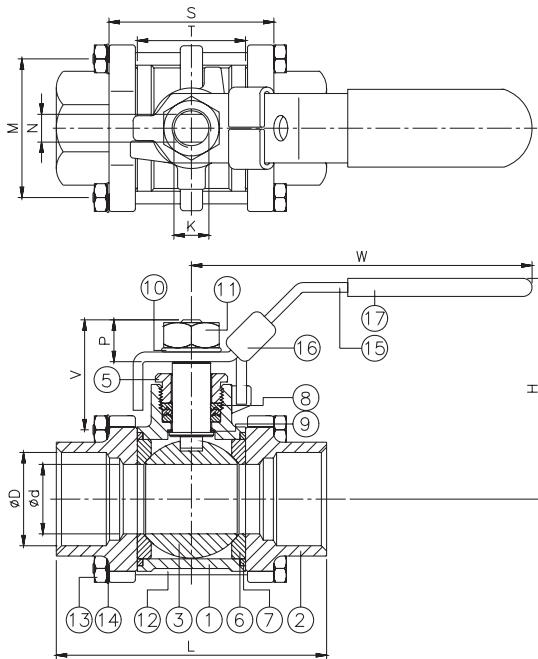

## FEATURES

- Full port, 1/4"~4" (DN8~DN100)
- W.P. : 1000 WOG (PN63)
- W.T. : -20°C~200°C (-4°F~392°F)
- Investment casting
- Blow-out proof stem
- Anti-static device (option)
- Locking device

- Socket weld ends conform to ANSI B16.11 & DIN 3239 part2



ITEM	PARTS	MATERIAL	
1	BODY	ASTM A351-CF8M	ASTM A216-WCB
2	CAP		
3	BALL	ASTM A351-CF8M	
4	STEM	ASTM A276-316	
5	GLAND NUT	AISI 304	
6	SEAT	RTFE / PTFE / CTFE	
7	SEAL		
8	PACKING	PTFE	
9	THRUST WASHER		
10	SPRING WASHER		
11	STEM NUT		
12	BOLT		
13	NUT	AISI 304	
14	SPRING WASHER		
15	HANDLE		
16	LOCKING DEVICE		
17	HANDLE SLEEVE	PVC	

DN	d	D	L	H	W	S	T	N	P	K	Weight (kg)
8	11.6	14	64.5	56	102	35.5	21.5	5	9.5	5/16"UNC	0.4
10	12.7	18	64.5	56	102	35.5	21.5	5	9.5	5/16"UNC	0.4
15	15	22	66	57	102	38	24	5	10.5	5/16"UNC	0.5
20	20	27.6	83.5	66	120.5	43	28	6.5	13.5	3/8"UNC	0.7
25	25	34.5	95	76	158.5	54	35	8	15.5	7/16"UNC	1.1
32	32	43	111.2	81	158.5	65	45	8	15.5	7/16"UNC	1.7
40	38	49.2	130	98	188	75	55	9	17.5	1/2"UNC	2.4
50	50	61.5	151	106	188	88	66	9	17.5	1/2"UNC	3.6
65	65	74	183	138	245	114	86	12	33	3/4"UNC	8.9
80	80	90	210.4	154	290	132	100	12	33	3/4"UNC	14.9
100	100	115	234	178	320	158	125	16	42	1"UNC	23.4

unit:mm

NPS	d	D	L	H	W	S	T	N	P	K	Weight (lb)
1/4"	0.46	0.55	2.54	2.2	4.02	1.4	0.85	0.2	0.37	5/16"UNC	0.9
3/8"	0.5	0.71	2.54	2.2	4.02	1.4	0.85	0.2	0.37	5/16"UNC	0.9
1/2"	0.59	0.87	2.6	2.24	4.02	1.5	0.94	0.2	0.41	5/16"UNC	1.1
3/4"	0.79	1.09	3.29	2.6	4.74	1.69	1.1	0.26	0.53	3/8"UNC	1.5
1"	0.98	1.36	3.74	2.99	6.24	2.13	1.38	0.31	0.61	7/16"UNC	2.4
1-1/4"	1.26	1.69	4.38	3.19	6.24	2.56	1.77	0.31	0.61	7/16"UNC	3.7
1-1/2"	1.5	1.94	5.12	3.86	7.4	2.95	2.17	0.35	0.69	1/2"UNC	5.3
2"	1.97	2.42	5.94	4.17	7.4	3.46	2.6	0.35	0.69	1/2"UNC	7.9
2-1/2"	2.56	2.91	7.2	5.43	9.65	4.49	3.39	0.47	1.3	3/4"UNC	19.6
3"	3.15	3.54	8.28	6.06	11.42	5.2	3.94	0.47	1.3	3/4"UNC	32.8
4"	3.94	4.53	9.21	7.01	12.6	6.22	4.92	0.63	1.65	1"UNC	51.6

unit:in

