



3-PC. SOCKET WELD END BALL VALVE

2011N

★ ECONOMIC PATTERN



FEATURES

- Full port, 1/4"~4" (DN8~DN100)
- W.P. : 1000 W OG (PN63)
- W.T. : -20°C~200°C (-4°F~392°F)
- Investment casting
- Blow-out proof stem
- Locking device
- **TA-Luft approved**
- **Length conform to DIN 3202/4-M3-2011N-M3 (option)**
- Socket weld ends conform to ANSI B16.11 & DIN 3239 part2

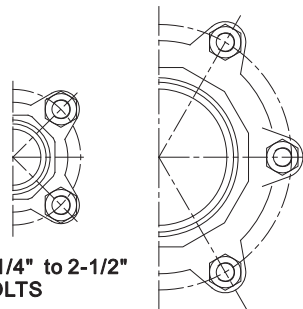
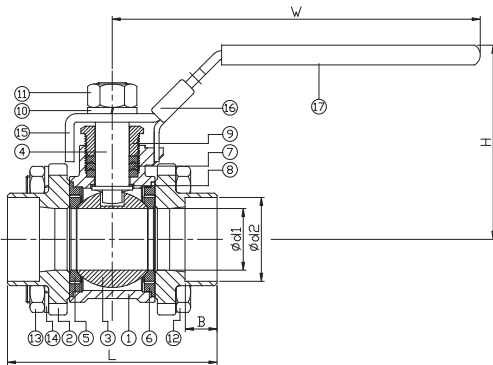

For 3" and 4" 6 BOLTS

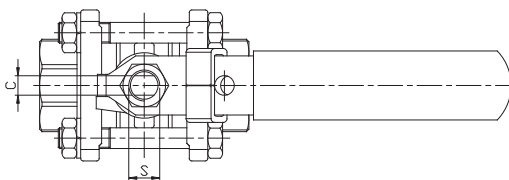

DN	d1	d2	B	L	H	W	C	S	Torque (N-M)	Weight (kg)
8	11.6	14.5	10	65	58.5	100	5	3/8"-24UNF	3.5	0.35
10	12.5	18	10	65	58.5	100	5	3/8"-24UNF	4	0.35
15	15	22	10	65	62	100	5	3/8"-24UNF	5.5	0.5
20	20	27.5	13	75	62	125	6.5	7/16"-20UNF	7.5	0.7
25	25	34	13	85	77	149	7.9	7/16"-20UNF	11	1
32	32	43	13	101	82	149	7.9	7/16"-20UNF	15	1.6
40	38	49	13	112	100	190	10	1/2"-20UNF	20	2.5
50	50	61	16	130	108	190	10	1/2"-20UNF	40	3.5
65	63	74	16	162	137	250	12	3/4"-10UNC	60	6.7
80	76	90	16	188	145	250	12	3/4"-10UNC	85	9.5
100	96	115.5	20	224	179	323	16	1"-8UNC	150	19.1

unit:mm

NPS	d1	d2	B	L	H	W	C	S	Torque (in-lb)	Weight (lb)
1/4"	0.46	0.57	0.39	2.56	2.3	3.94	0.2	3/8"-24UNF	30.98	0.77
3/8"	0.49	0.71	0.39	2.56	2.3	3.94	0.2	3/8"-24UNF	35.4	0.77
1/2"	0.59	0.87	0.39	2.56	2.44	3.94	0.2	3/8"-24UNF	48.68	1.1
3/4"	0.79	1.08	0.51	2.95	2.44	4.92	0.26	7/16"-20UNF	66.38	1.54
1"	0.98	1.34	0.51	3.35	3.03	5.87	0.31	7/16"-20UNF	97.36	2.2
1-1/4"	1.26	1.69	0.51	3.98	3.23	5.87	0.31	7/16"-20UNF	132.76	3.53
1-1/2"	1.5	1.93	0.51	4.41	3.94	7.48	0.39	1/2"-20UNF	177.01	5.51
2"	1.97	2.4	0.63	5.12	4.25	7.48	0.39	1/2"-20UNF	354.03	7.72
2-1/2"	2.48	2.91	0.63	6.38	5.39	9.84	0.47	3/4"-10UNC	531.04	14.77
3"	2.99	3.54	0.63	7.4	5.71	9.84	0.47	3/4"-10UNC	752.31	20.94
4"	3.78	4.55	0.79	8.82	7.05	12.72	0.63	1"-8UNC	1327.61	42.11

unit:in

ITEM	PARTS	MATERIAL		
1	BODY	ASTM A351-CF8M	ASTM A216-WCB	ASTM A351-CF3
2	CAP			
3	BALL	ASTM A351-CF8M		
4	STEM	ASTM A276-316		
5	SEAT			
6	SEAL	PTFE		
7	PACKING			
8	THRUST WASHER			
9	GLAND NUT			
10	SPRING WASHER			
11	STEM NUT			
12	BOLT	AISI 304		
13	NUT			
14	SPRING WASHER			
15	HANDLE			
16	LOCKING DEVICE			
17	HANDLE SLEEVE	PVC		



8F., No.201, Sec. 2, Tiding Blvd., Neihu District, Taipei City 114, Taiwan R.O.C.
TEL: +886-2-26585800 FAX: +886-2-26582266 / 27997766

[Http://www.haitima.com.tw](http://www.haitima.com.tw)
Email: haitima@seed.net.tw