

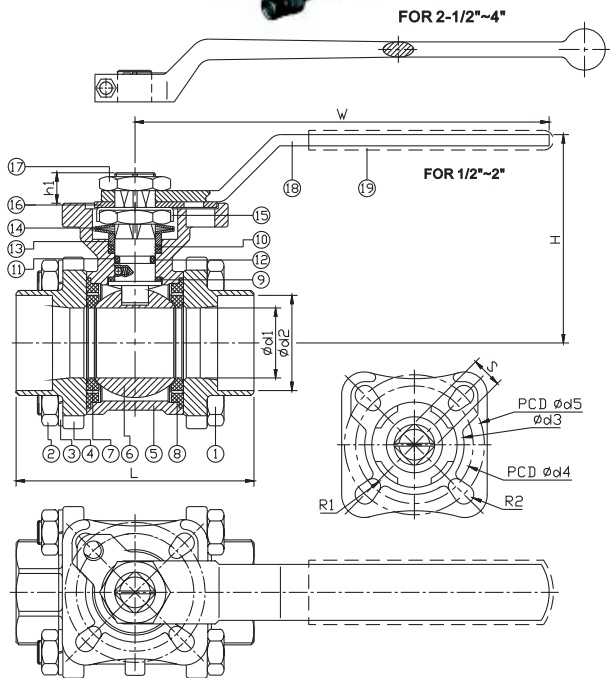

3-PC. SOCKET WELD END BALL VALVE

2011ND

★ ECONOMIC PATTERN



FEATURES

- Full port, 1/4"~4" (DN8~DN100)
- W.P. : 1000 WOG (PN63)
- W.T. : -20°C~200°C (-4°F~392°F)
- Investment casting
- Blow-out proof stem
- Live-loading device
- Locking device
- Anti-static device
- ISO 5211 direct mounting pad
- Length conform to DIN 3202/4-M3-2011ND-M3 (option)
- Automation accessories (option)

- Socket weld ends conform to ANSI B16.11 & DIN 3239 part2

ITEM	PARTS	MATERIAL
1	BOLT	AISI 304
2	NUT	
3	SPRING WASHER	
4	CAP	ASTM A351-CF8M
5	BODY	
6	BALL	PTFE / RTFE
7	SEAT	
8	SEAL	PTFE
9	THRUST WASHER	
10	PACKING	VITON
11	O-RING	
12	STEM	ASTM A276-316
13	GLAND RING	AISI 304
14	BELLEVILLE WASHER	AISI 301
15	LOCKING WASHER	AISI 304
16	LOCKING DEVICE	
17	STEM NUT	
18	HANDLE	PVC
19	HANDLE SLEEVE	

DN	d1	d2	L	H	W	S	h1	d3	d4	d5	R1	R2	Torque (N·M)
15	15	22	65	60	120	9	8.5	31	36	42	2.75	2.75	7.5
20	20	27.5	75	64									11
25	25	34	85	74									14
32	32	43	101	79	178	14	13.5	56	50	70	3.5	4.5	21
40	38	49	112	95									27
50	50	61	130	103									50
65	63	74	162	123	340	17	20.5	76	70	102	4.5	5.5	85
80	76	90	188	131.5									97
100	96	115.5	224	165.5									150

unit : mm

NPS	d1	d2	L	H	W	S	h1	d3	d4	d5	R1	R2	Torque (in·lb)
1/2"	0.59	0.87	2.56	2.36	4.72	0.35	0.33	1.22	1.42	1.65	0.11	0.11	66.38
3/4"	0.79	1.08	2.95	2.52									97.36
1"	0.98	1.34	3.35	2.91	5.83	0.43	0.43	1.4	1.65	1.97	0.11	0.14	123.91
1-1/4"	1.26	1.69	3.98	3.11									185.86
1-1/2"	1.5	1.93	4.41	3.74	7.01	0.55	0.53	2.2	1.97	2.76	0.14	0.18	238.97
2"	1.97	2.4	5.12	4.06									442.54
2-1/2"	2.48	2.91	6.38	4.84	13.39	0.67	0.81	2.99	2.76	4.02	0.18	0.22	752.31
3"	2.99	3.54	7.4	5.18									858.52
4"	3.78	4.55	8.82	6.52									1327.61

unit : in



8F., No.201, Sec. 2, Tiding Blvd., Neihu District, Taipei City 114, Taiwan R.O.C.
 TEL: +886-2-26585800 FAX: +886-2-26582266 / 27997766

[Http://www.haitima.com.tw](http://www.haitima.com.tw)
 Email: haitima@seed.net.tw