

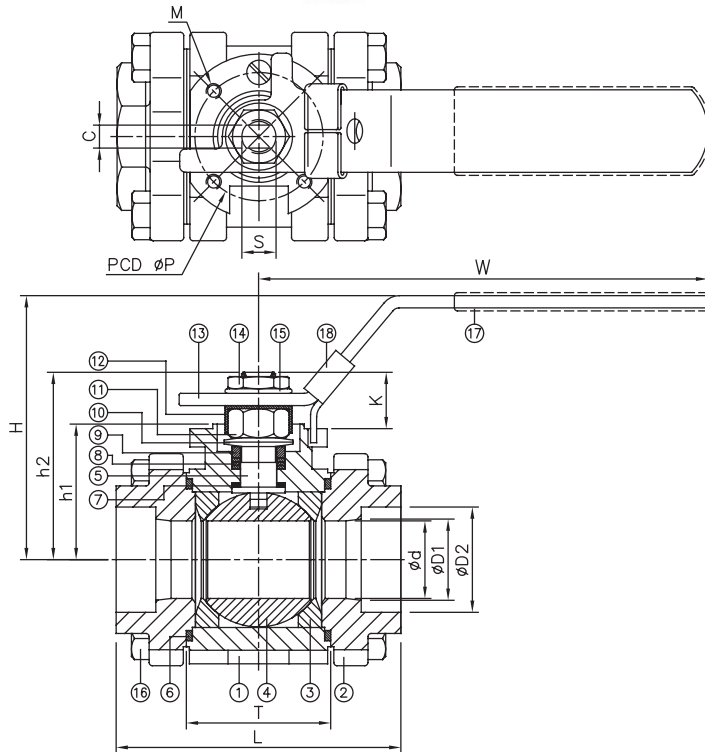

FEATURES

- Full port, 1/4"~2" (DN8~DN50)
- W.P. : 3000 WOG (PN200)
- W.T. : -20°C~260°C (-4°F~500°F)
- Investment casting
- Blow-out proof stem
- Live-loading design
- Anti-static device (option)
- Locking device
- ISO 5211 Mounting pad
- **ASME B16.34 Wall thickness**
- **NACE MR0175 (option)**

- Socket weld ends conform to ANSI B16.11 & DIN 3239 part2



ITEM	PARTS	MATERIAL
1	BODY	ASTM A351-CF8M
2	CAP	ASTM A351-CF3M
3	SEAT	PEEK / DELRIN
4	BALL	ASTM A351-CF8M
5	STEM	ASTM A276-316
6	SEAL	RTFE
7	THRUST WASHER	RTFE / CTFE
8	PACKING	
9	GLAND RING	AISI 304
10	BELLEVILLE WASHER	AISI 301
11	STEM NUT	AISI 304
12	LOCKING WASHER	
13	HANDLE	
14	HANDLE NUT	
15	SPRING WASHER	PVC
16	BOLT	
17	HANDLE SLEEVE	AISI 304
18	LOCKING DEVICE	

- DELRIN SEAT MAX USING TEMPERATURE: 80°C

DN	d	D1	D2	L	T	H	W	h1	h2	C	P	M	K	S	Torque (N-m)
8	11.6	-	14	74.8	30.6	61.2	114.5	31.5	45.8	5.7	36	M5	15.3	3/8"-24UNF	8.8
10	12.7	-	18	74.8	30.6	61.2	114.5	31.5	45.8	5.7	36	M5	15.3	3/8"-24UNF	8.8
15	14.3	15.8	22	74.8	30.6	61.2	114.5	31.5	45.8	5.7	36	M5	15.3	3/8"-24UNF	8.8
20	20.7	21	27.5	80	37.8	81.5	147	39.8	55.1	7.5	42	M5	16.8	7/16"-20UNF	16.1
25	25.4	26.6	34.5	93	47	86.2	147	44.4	60	7.5	42	M5	17	7/16"-20UNF	16.1
32	31.5	35	43	109.5	54.3	96.3	178	45.5	73.6	8.6	50	M6	29.6	9/16"-18UNF	32.5
40	38	41	49.5	120.1	62.3	101.1	178	50.3	78.4	8.6	50	M6	29.6	9/16"-18UNF	45.5
50	50.8	52.5	61.5	139.6	78.8	111.6	178	60.8	88.9	8.6	50	M6	29.6	9/16"-18UNF	52

unit:mm

NPS	d	D1	D2	L	T	H	W	h1	h2	C	P	M	K	S	Torque (in-lb)
1/4"	0.56	-	0.55	2.94	1.2	2.41	4.51	1.24	1.8	0.22	1.42	M5	0.6	3/8"-24UNF	77.9
3/8"	0.56	-	0.71	2.94	1.2	2.41	4.51	1.24	1.8	0.22	1.42	M5	0.6	3/8"-24UNF	77.9
1/2"	0.56	0.62	0.87	2.94	1.2	2.41	4.51	1.24	1.8	0.22	1.42	M5	0.6	3/8"-24UNF	77.9
3/4"	0.81	0.83	1.08	3.15	1.49	3.21	5.79	1.57	2.17	0.3	1.65	M5	0.66	7/16"-20UNF	142.5
1"	1	1.05	1.36	3.67	1.85	3.39	5.79	1.75	2.36	0.3	1.65	M5	0.67	7/16"-20UNF	142.5
1-1/4"	1.24	1.38	1.69	4.31	2.14	3.79	7.01	1.79	2.9	0.34	1.97	M6	1.17	9/16"-18UNF	287.6
1-1/2"	1.5	1.61	1.95	4.73	2.45	3.98	7.01	1.98	3.09	0.34	1.97	M6	1.17	9/16"-18UNF	402.7
2"	2	2.07	2.42	5.5	3.1	4.39	7.01	2.39	3.5	0.34	1.97	M6	1.17	9/16"-18UNF	460.2

unit:in

