



# 2-PC. SCREWED END BALL VALVE

# 2009D



## FEATURES

- Full port, 1/4"~2" (DN8~DN50)
- W.P. : 1000 WOG (PN63)
- W.T. : -20°C~200°C (-4°F~392°F)
- Investment casting
- Blow-out proof stem
- Live-loading device
- Anti-static device
- Locking device
- ISO 5211 Direct mounting pad
- **Length conform to DIN 3202/4-M3**
- **Automation accessories (option)**
- Thread type : ASME B1.20.1 (NPT)  
DIN2999 & BS21  
ISO228/1 & ISO7/1

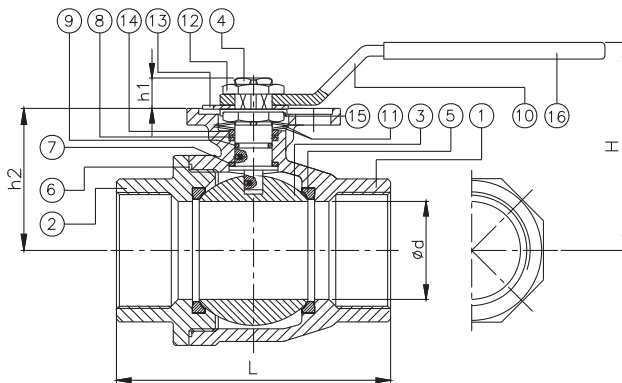
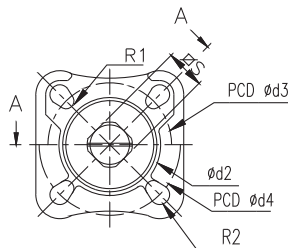

ITEM	PARTS	MATERIAL	
1	BODY	ASTM A351-CF8M	ASTM A216-WCB
2	CAP		
3	BALL	ASTM A351-CF8M	
4	STEM	ASTM A276-316	
5	SEAT	PTFE / RTFE	
6	SEAL	PTFE	
7	THRUST WASHER		
8	PACKING	VITON	
9	O-RING		
10	HANDLE	AISI 304	
11	BELLEVILLE WASHER	AISI 301	
12	STEM NUT	AISI 304	
13	LOCKING DEVICE		
14	GLAND RING		
15	LOCKING WASHER	PVC	
16	HANDLE SLEEVE		

DN	d	L	H	ISO 5211	S	h1	h2	d2	d3	d4	R1	R2	Torque N-m	
													Action	Breakaway
8	8	75	64	F03/F04	9	8	39	31	36	42	2.75	2.75	2.5	6.4
10	10												2.5	6.4
15	15						2.5						6.4	
20	20	80	70	F04/F05	11	9	44	35.5	42	50	2.75	3.5	3.3	10
25	25	90.5	74				47.5						5.8	11
32	32	110	80				53						7.7	25.5
40	38	120	98	F05/F07	14	13	64.5	56	50	70	3.5	4.5	9.6	34.5
50	50	140	107				73						15.3	52.3

unit:mm

NPS	d	L	H	ISO 5211	S	h1	h2	d2	d3	d4	R1	R2	Torque in-lb	
													Action	Breakaway
1/4"	0.31	2.95	2.52	F03/F04	0.35	0.31	1.54	1.22	1.42	1.65	0.11	0.11	22.13	56.65
3/8"	0.39												22.13	56.65
1/2"	0.59						22.13						56.65	
3/4"	0.79	3.15	2.76	F04/F05	0.43	0.35	1.73	1.4	1.65	1.97	0.11	0.14	29.21	88.51
1"	0.98	3.56	2.91				1.87						51.34	97.36
1-1/4"	1.26	4.33	3.15				2.09						68.15	225.7
1-1/2"	1.5	4.72	3.86	F05/F07	0.55	0.51	2.54	2.2	1.97	2.76	0.14	0.18	84.97	305.36
2"	1.97	5.51	4.21				2.87						135.42	462.91

unit:in



8F., No.201, Sec. 2, Tiding Blvd., Neihu District, Taipei City 114, Taiwan R.O.C.  
TEL: +886-2-26585800 FAX: +886-2-26582266 / 27997766

[Http://www.haitima.com.tw](http://www.haitima.com.tw)  
Email: [haitima@seed.net.tw](mailto:haitima@seed.net.tw)